

Amarillo® Gear Company

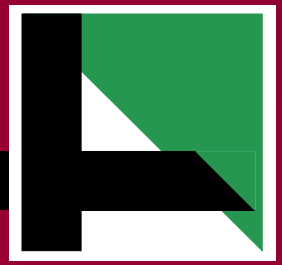

T.M.

# AUTOMATIC COMBINATION GEAR DRIVE



## AMARILLO AUTOMATIC COMBINATION DRIVE

The **Amarillo Automatic Combination Drive** offers a reliable system for automatically changing from electric motor to the stand-by power source. There is no need for manually changing the clutch to transmit power with the gear drive.

The system is designed so that during motor operation only the pump headshaft and the outer drive body (726) of the automatic clutch rotates. A steady bearing is supplied to insure that the headshaft stays in alignment. The stand for the electric motor is furnished with the drive and is available in standard NEMA motor sizes as listed in Table 1.

**The Automatic Combination Clutch** is available on the Models 30 through 1000. Additional sizes may be available upon request. **THE FACTORY SHOULD BE CONSULTED ON ALL APPLICATIONS.**

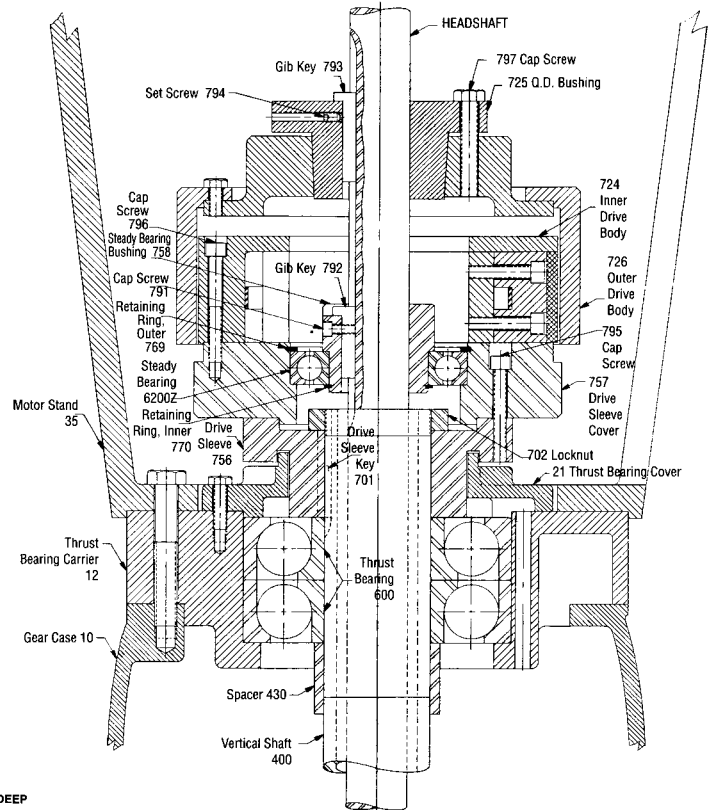
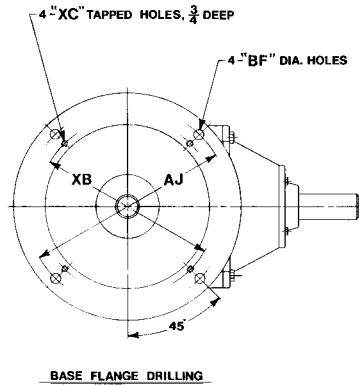
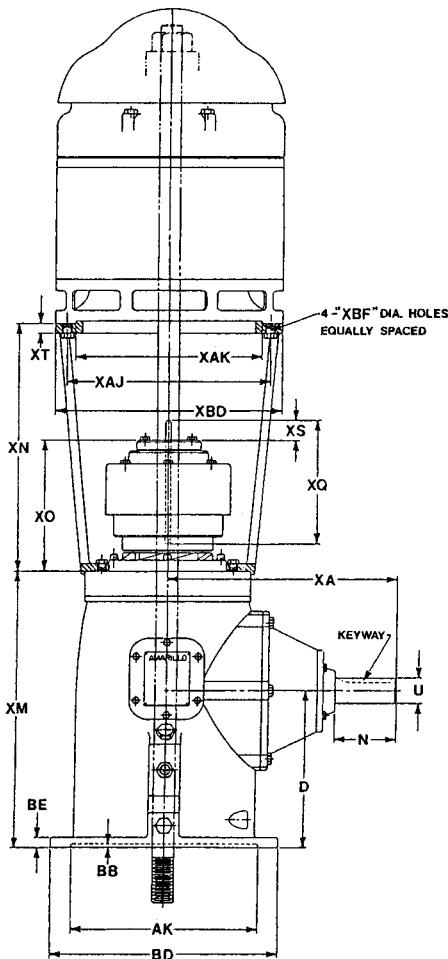

**NOTE:**  
THE ELECTRIC MOTOR  
SUPPORTS THE PUMP  
THRUST AT ALL TIMES

**TABLE 1**  
**MOTOR STAND BASE DIMENSIONS**  
Sizes available for NEMA motor dimensions at standard cost.

"XBD"	30	40A	40B	60A	80A	100A	125A	150A	200A	250	300	350	450A	500A	600A	750A	1000G	XAJ	XAK	XBF
10	X																	9 <sup>1</sup> / <sub>8</sub>	8 <sup>1</sup> / <sub>4</sub>	7 <sup>1</sup> / <sub>16</sub>
12	X	X	X	X	X	X	X											9 <sup>1</sup> / <sub>8</sub>	8 <sup>1</sup> / <sub>4</sub>	7 <sup>1</sup> / <sub>16</sub>
16 1/2	X	X	X	X	X	X	X	X	X	X	X	X						14 <sup>3</sup> / <sub>4</sub>	13 <sup>1</sup> / <sub>2</sub>	11 <sup>1</sup> / <sub>16</sub>
20				X	X	X	X	X	X	X	X	X	X	X	X			14 <sup>3</sup> / <sub>4</sub>	13 <sup>1</sup> / <sub>2</sub>	11 <sup>1</sup> / <sub>16</sub>
24 1/2				X	X	X	X	X	X	X	X	X	X	X	X	X		14 <sup>3</sup> / <sub>4</sub>	13 <sup>1</sup> / <sub>2</sub>	11 <sup>1</sup> / <sub>16</sub>
30 1/2																	X	26	22	13 <sup>1</sup> / <sub>16</sub>

\*Other sizes are available. Contact the factory for details.

**TABLE 2  
DIMENSIONS**

MODEL	D	N	HORIZONTAL SHAFT U			AJ	AK	BB	BD	BE	BF
			NOM	ACT.	KEYWAY						
CA30	6 3/4	2 5/8	1 1/4	1.249	5/16 X 5/32	9 1/8	8 1/4	3/16	10	5/8	7/16
CA40A	8 1/2	4 3/8	1 1/2	1.499	3/8 X 3/16	9 1/8	8 1/4	1/4	12	13/16	7/16
CA40B	8 1/2	4 3/8	1 1/2	1.499	3/8 X 3/16	14 3/4	13 1/2	1/4	16 1/2	13/16	11/16
CA60A	11 1/2	4 1/4	1 1/2	1.499	3/8 X 3/16	14 3/4	13 1/2	1/4	16 1/2	3/4	11/16
CA80A	11 1/2	4 1/4	1 7/8	1.874	3/8 X 3/16	14 3/4	13 1/2	1/4	16 1/2	3/4	11/16
CA100A	11 1/2	4 1/4	1 7/8	1.874	3/8 X 3/16	14 3/4	13 1/2	1/4	16 1/2	3/4	11/16
CA125A	11 1/2	4 1/4	1 7/8	1.874	3/8 X 3/16	14 3/4	13 1/2	1/4	16 1/2	3/4	11/16
CA150A	11 1/2	4 1/2	2 7/16	2.436	5/8 X 5/16	14 3/4	13 1/2	1/4	16 1/2	3/4	11/16
CA200A	13 3/4	5 1/4	2 7/16	2.436	5/8 X 5/16	18 1/4	13 1/2	1/4	20	1 1/8	11/16
CA250	13 3/4	5 1/4	2 15/16	2.936	3/4 X 3/8	18 1/4	13 1/2	1/4	20	1 1/8	11/16
*CA300	13 3/4	5 1/4	2 15/16	2.936	3/4 X 3/8	18 1/4	13 1/2	1/4	20	1 1/8	11/16
*CA350	13 3/4	5 1/4	2 15/16	2.936	3/4 X 3/8	18 1/4	13 1/2	1/4	20	1 1/8	11/16
CA450A	16	6	2 15/16	2.936	3/4 X 3/8	23	13 1/2	1/4	24 1/2	1 1/8	13/16
CA500A	16	6	3 1/8	3.124	3/4 X 3/8	23	13 1/2	1/4	24 1/2	1 1/8	13/16
CA600A	16	6	3 3/4	3.749	7/8 X 7/16	23	13 1/2	1/4	24 1/2	1 1/8	13/16
CA750A	18	6	3 3/4	3.749	7/8 X 7/16	23	13 1/2	1/4	24 1/2	1 1/8	13/16
CA1000G	21	8	4	3.998	1 X 1/2	28 3/4	22	1/4	30 1/2	1 1/4	13/16

MODEL	XA	XB	XC	XM	XN	XO	XQ	XS	XT	MAX BX**
CA30	10 7/8	—	—	12 1/4	12 1/2	8 3/8	8 1/2	1 5/8	7/16	1
CA40A	15 5/8	—	—	16 3/16	16	9 3/8	9 1/2	2	5/8	1 1/4
CA40B	15 5/8	—	—	16 3/16	16	9 3/8	9 1/2	2	5/8	1 1/4
CA60A	16 3/4	—	—	20 1/4	18	9 9/16	9 1/2	2	3/4	1 1/2
CA80A	16 3/4	—	—	20 3/8	18	9 9/16	9 1/2	2	3/4	1 1/2
CA100A	16 3/4	—	—	20 3/8	18	11 1/16	12	2 1/2	3/4	1 1/2
CA125A	16 3/4	—	—	20 3/8	18	11 1/16	12	2 1/2	3/4	1 1/2
CA150A	18 3/4	—	—	20 3/8	18	11 3/16	12	2 1/2	3/4	1 11/16
CA200A	20 3/4	14 3/4	5/8-11 NC	24 7/8	20	11 9/16	12	2 1/2	7/8	2
CA250	22 3/8	14 3/4	5/8-11 NC	25 1/16	20	11 3/16	12	2 1/2	7/8	2 3/16
*CA300	22 3/8	14 3/4	5/8-11 /NC	25 1/16	20	13	14 1/4	3	7/8	2 3/16
*CA350	22 3/8	14 3/4	5/8-11 NC	25 1/16	20	13	14 1/4	3	7/8	2 3/16
CA450A	†25 1/2	14 3/4	5/8-11 NC	30 1/8	27	15 3/8	17	4	1	2 7/16
CA500A	†25 1/2	14 3/4	5/8-11 NC	30 1/8	27	15 3/8	17	4	1	2 7/16
CA600A	†25 1/2	14 3/4	5/8-11 NC	30 1/8	27	15 3/8	17	4	1	2 7/16
CA750A	†26 3/4	14 3/4	5/8-11 NC	34 1/4	27	17 1/4	18 3/8	4 1/4	1 1/8	2 7/16
CA1000G	36 7/8	26	3/4-10 NC	42	30	21 9/16	20	4 1/4	1 1/4	2 15/16

† “XA” dimension shown applies to 1:1 ratio and speed increasing ratios only. Request certified drawing for others.

\* Models 300 and 350 furnished with heat exchanger.

\*\* Contact the factory for maximum coupling bore for special rotation drive with 1:2, 2:5 and 1:3 ratio.

■ Dimensions are for the vertical shaft speeds of 1760 RPM. Contact factory for dimensions at other speeds.

**TABLE 3**

Vertical Shaft Engagement speeds for clutch (1760 RPM pumps)

MODEL	RPM	MODEL	RPM	MODEL	RPM
CA30	820	CA100A, CA125A	770	CA450A, CA500A	450
CA40A, CA40B	940	CA200A, CA250	550	CA600A, CA750A	560
CA60A, CA80A, CA150A	670	CA300, CA350	630	CA1000G	460

## INSTALLATION INSTRUCTIONS FOR AMARILLO AUTOMATIC COMBINATION GEAR DRIVES

### 1.0 Pre-Installation Instructions.

- 1.1 Refer to the cross section print during installation of the combination drive.
- 1.2 Remove the guards from the motor stand (35).
- 1.3 Remove the outer drive body (726) with the QD bushing (725). (It will just lift off.)
- 1.4 Remove the inner drive body (724) by removing the six cap screws (796).
- 1.5 Remove the drive sleeve cover (757), with the steady bearing (6200Z) and bearing bushing (758), by removing the cap screws (795).
- 1.6 Remove the outer retaining ring (769).
- 1.7 Remove the steady bearing (6200Z) and steady bearing bushing (758) from the drive sleeve cover (757). If a brass punch is required to remove the bearing from the drive sleeve cover, be sure to tap only the outer race of bearing.
- 1.8 Remove the cap screw (791) from the bearing bushing (758) and remove the gib key (792).
- 1.9 Remove the QD bushing (725) from the outer drive body (726) by removing the three cap screws (797). Insert the screws into the threaded holes in the bushing and alternately tighten them until the bushing breaks loose.

### 2.0 Installation Instructions

- 2.1 Place the gear drive on the pump discharge head, align with the engine and secure with the correctly sized bolts. Refer to the **Operation and Maintenance Instructions for Amarillo Right Angle Gear Drives**.
- 2.2 Lower the headshaft down through the center of the gear drive. Be sure not to hit the oil tube located in the bottom of the gear drive.
- 2.3 Couple the headshaft to the pump shaft.
- 2.4 Check the headshaft to make sure that the keyway is of sufficient length so that it will not bind on the bearing bushing gib key (792) after the pump impellers have been adjusted to the manufacturer's recommendations. Also, the keyway should extend up from the gear drive sufficiently to allow installation of the QD bushing gib key (793).
- 2.5 Place the drive sleeve cover (757) on the drive sleeve (756) and alternately tighten the cap screws (795) to make sure that the cover is pulled down squarely.
- 2.6 Slide the steady bearing bushing (758) and steady bearing (6200Z) onto the headshaft.
- 2.7 Insert the gib key (792) into the steady bearing bushing (758) and retain with the cap screw (791). Check the fit of these components at this time. The bearing bushing and gib key assembly must slide freely on the headshaft.
- 2.8 After obtaining a free sliding fit of the steady bearing bushing (758) on the headshaft, slide the bearing (6200Z) down into the drive sleeve cover (757).
- 2.9 Install the outer retaining ring (769).
- 2.10 Place the inner drive body (724) on the drive sleeve cover (757) and insert the six cap screws (796). Alternately tighten the screws until tight, making sure the drive body is pulled down squarely.
- 2.11 Slide the outer drive body (726) over the inner drive body (724).
- 2.12 Slide the QD bushing (725) onto the headshaft.
- 2.13 Install the electric motor according to the motor manufacturer's instructions.
- 2.14 Install the pump adjusting nut at the top of the motor and adjust the pump impellers according to the pump manufacturer's instructions.
- 2.15 After adjusting the pump impellers, locate the QD bushing (725) on the headshaft to the same height as the 'XO' dimension shown on the dimension print.
- 2.16 Insert the gib key (793) and tighten the set screw (794) until the QD bushing (725) does not move.
- 2.17 Insert the three cap screws (797) into the through holes in the QD bushing (725) and thread into the outer drive body (726). Make a mark at the top of QD bushing (725) to make sure it doesn't move during the following operations.  
**NOTE:** Do not use a lubricant or anti seize compound on the threads or tapered surfaces of these components.
- 2.18 Alternately tighten the screws until the outer drive body (726) is seated on the QD bushing (725), at approximately 1/2 the torque value listed in Table 4 for the particular model of combination being installed. The drive body should be pulled up squarely and be approximately 1/2 inch above the shoulder in the drive sleeve cover (757).
- 2.19 If possible, rotate the pump shaft by hand to check for runout in the outer drive body (726) and to make sure no parts are dragging or binding.
- 2.20 Continue to alternately tighten the cap screws (797) until the torque value listed in Table 4 is obtained.
- 2.21 Reattach the motor stand guards to the motor stand (35).

**TABLE 4**

MODEL	TORQUE (IN LBS.)
CA30, CA40A	180
CA60A, CA80A, CA100A, CA125A	360
CA150A, CA200A, CA250	720
CA300, CA350, CA450A, CA500A	900
CA600A, CA750A, CA1000G	1620